

# Pitch

# 0.25mm

# Length

# 4.2mm

**BGA** **LGA** **SOP**  
**QFP** **QFN** etc.

Ultra Fine Pitch

### Pin Outline

Unit: mm [inch]

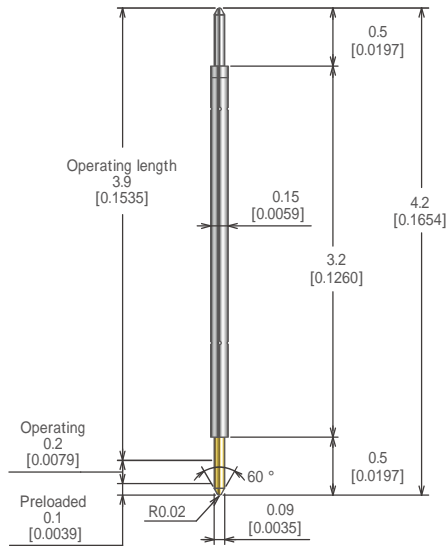

### Specifications

(Approximate Average Values)

Mechanical Specifications	
Spring Force at Operating Travel	14gf (0.49oz.)
Operating Travel	0.3mm (0.0118inch)
Operating Temperature	45 to 125
Life Span at Operating Travel	80K Cycles
Electrical Specifications	
Current Rating (Continuous)	0.3A
Self Inductance	1.71nH
Bandwidth @ 1dB	29.0GHz
DC Resistance	0.2ohm
Material and Finishes	
Bottom Plunger	Steel / Au Plated
Barrel	Alloy / No Plating
Spring	Music Wire / Au Plated

### Top Plunger & Item Number

#### KHS025 001CP

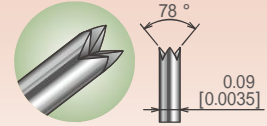

Material : Pd Alloy  
Plating :

#### KHS025 002RP

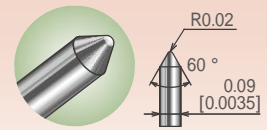

Material : Pd Alloy  
Plating :

\*Top Plunger : Please refer to the table on the right.

### Socket Outline

Unit: mm [inch]

### Force Chart

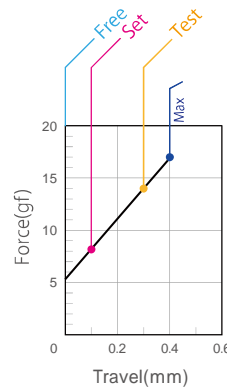
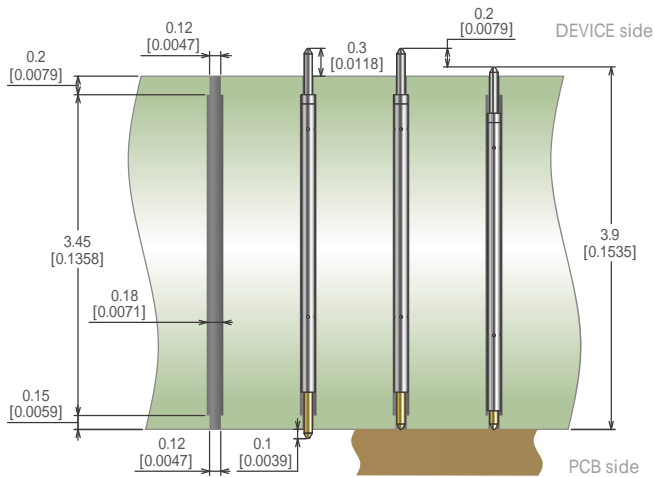

Free Set Test

### Insertion Loss Data

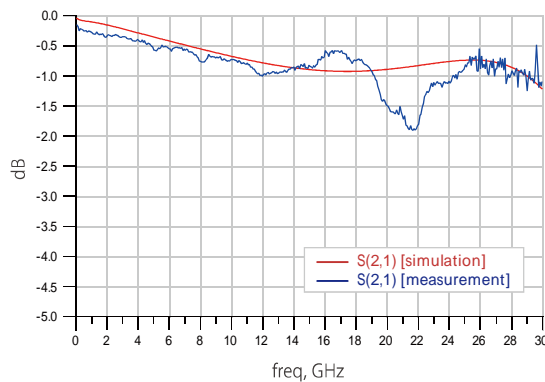

### Life Test Data

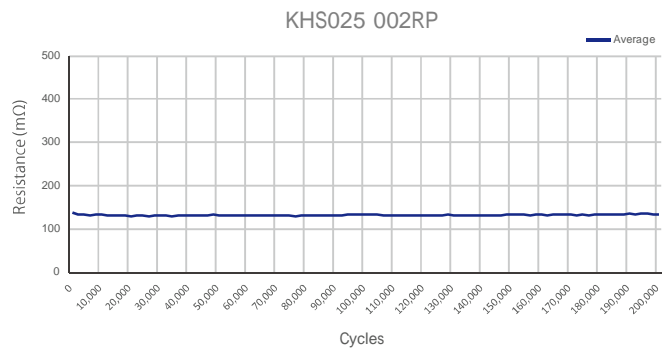

# KITA