

Kelvin 040

Pin Dia.
0.30mm

Length
3.90mm

Pin Outline

Unit: mm [inch]

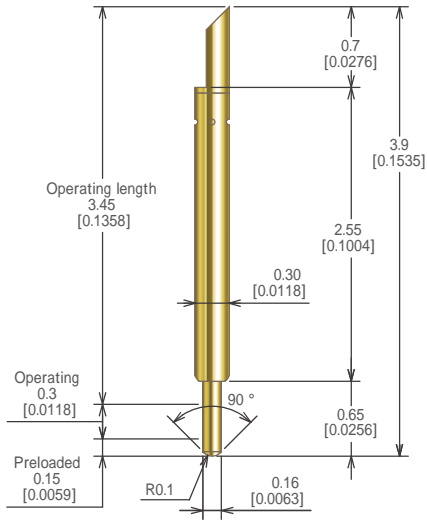

Specifications

(Approximate Average Values)

Mechanical Specifications	
Spring Force at Operating Travel	22gf (0.78oz.)
Operating Travel	0.45mm (0.0177inch)
Operating Temperature	45 to 125
Life Span at Operating Travel	1000K Cycles
Electrical Specifications	
Current Rating (Continuous)	2.7A (KHS040 009W1)
	1.5A (KHS040 010NW2)
Self Inductance	1.10nH
Bandwidth @ 1dB	26.5GHz
DC Resistance	0.05ohm
Material and Finishes	
Bottom Plunger	BeCu / Au Plated
Barrel	Alloy / Au Plated
Spring	Music Wire / Au Plated

Top Plunger & Item Number

KHS040 009W1

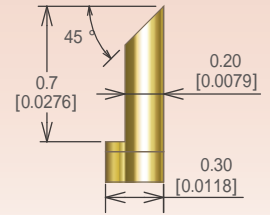
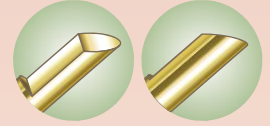

Material : BeCu
Plating : Au

*Top Plunger : Please refer to the table on the right.

Socket Outline

Unit: mm [inch]

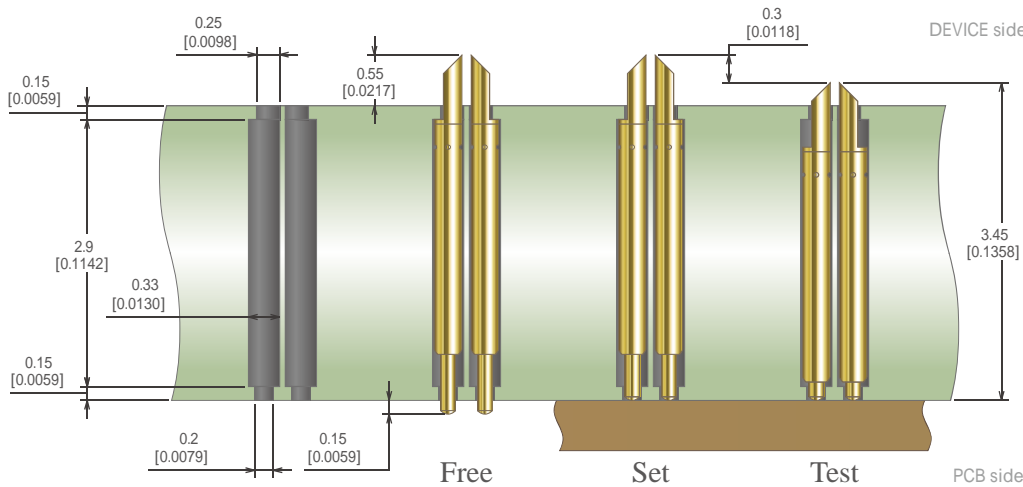

KHS040 010NW2

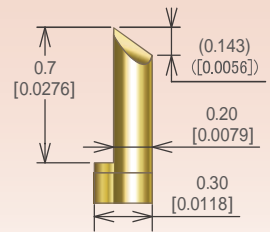
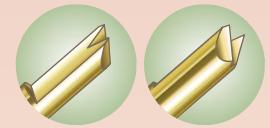

Material : BeCu
Plating : Au Alloy

Pin Arrangement

Peripheral type package

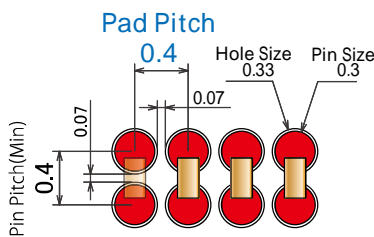

Grid Array type package

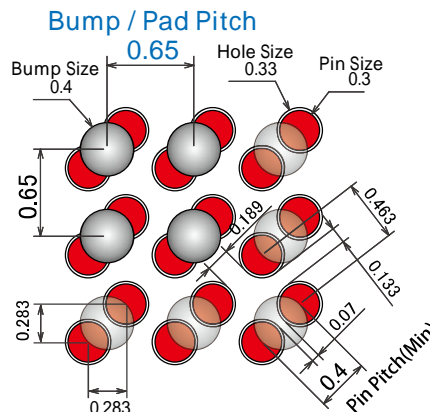

Applications (Reference)

Peripheral

- Package Type QFN, DFN etc.
- Pad/Bump Pitch 0.4mm

Grid Array

- Package Type BGA, LGA etc.
- Pad/Bump Pitch 0.65mm