

Kelvin 030

Pin Dia. **0.20mm** Length **4.50mm**

Pin Outline

Unit: mm [inch]

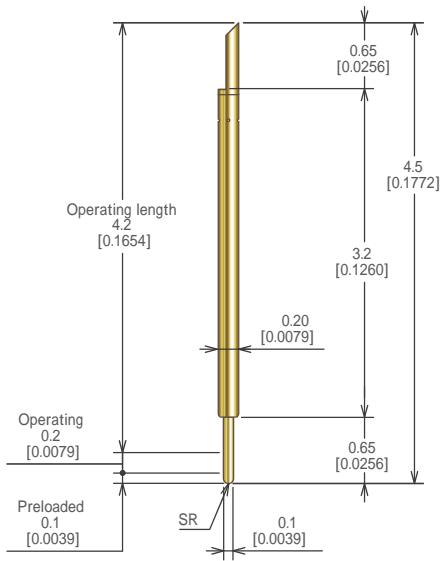

Specifications

(Approximate Average Values)

Mechanical Specifications	
Spring Force at Operating Travel	15gf (0.53oz.)
Operating Travel	0.3mm (0.0118inch)
Operating Temperature	45 to 125
Life Span at Operating Travel	1000K Cycles
Electrical Specifications	
Current Rating (Continuous)	0.9A
Self Inductance	1.62nH
Bandwidth @ 1dB	17.7GHz
DC Resistance	0.2ohm
Material and Finishes	
Bottom Plunger	BeCu / Au Plated
Barrel	Alloy / Au Plated
Spring	Music Wire / Au Plated

*Top Plunger : Please refer to the table on the right.

Top Plunger & Item Number

KJS030 001W1

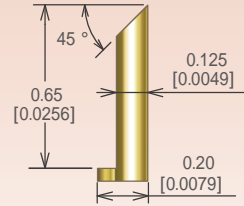
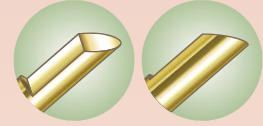

Material : BeCu
Plating : Au

Socket Outline

Unit: mm [inch]

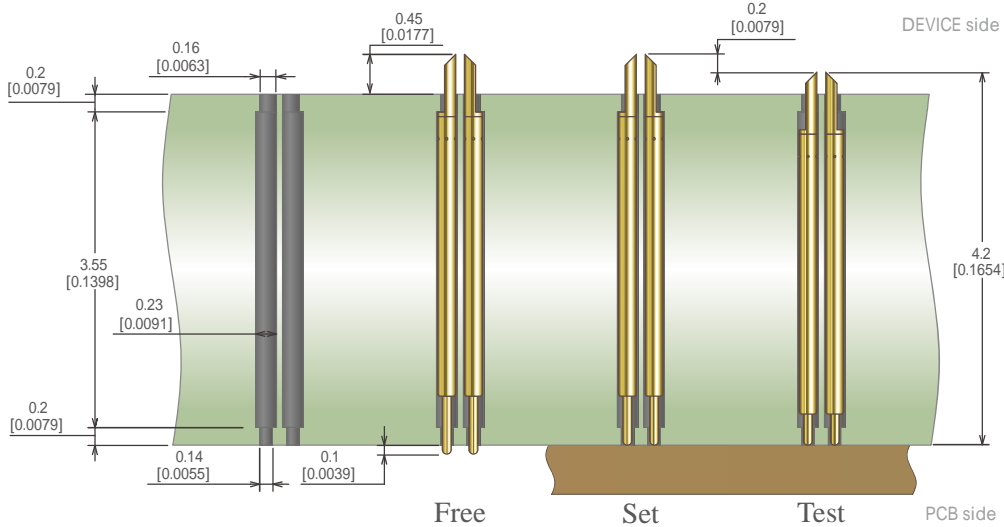

KJS030 002NW2

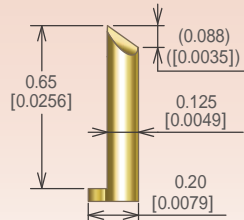
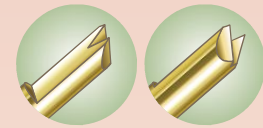

Material : BeCu
Plating : Au Alloy

Pin Arrangement

Peripheral type package

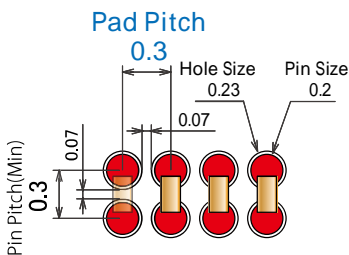

Grid Array type package

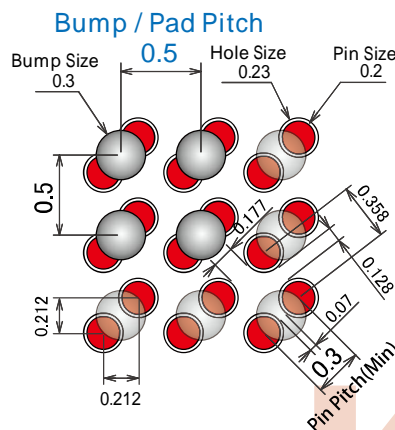

Applications

(Reference)

Peripheral

- Package Type QFN, DFN etc.
- Pad/Bump Pitch 0.3mm

Grid Array

- Package Type BGA, LGA etc.
- Pad/Bump Pitch 0.5mm